

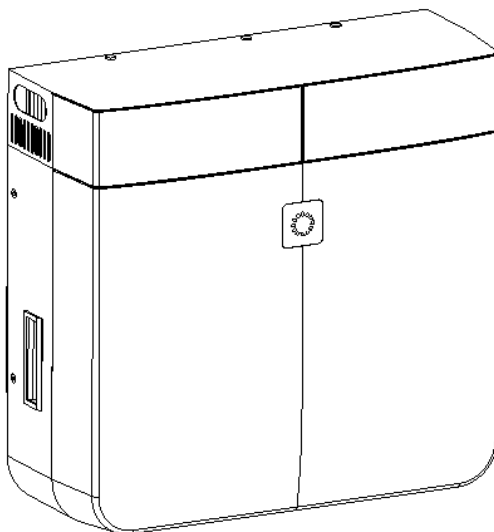

Operating Manual

AIO2-BTLV Series



Version:DM-AIO2-BTLV-EN 1.0

CONTENTS

1.	About This Manual	1
1.1	Products Covered by This Manual	1
1.2	Symbols Used	1
1.3	Storage of the Manual	1
2.	Safety.....	2
2.1	Intended Use.....	2
2.2	Important Safety Instructions	2
3.	Scope of Delivery	3
4.	Product Description	4
5.	Electrical schematic for AIO2-BTLV	5
6.	Mounting	5
6.1	Requirements for Mounting.....	5
6.2	Mounting the Battery (5kWh)	7
6.3	Mounting the Battery (10kWh)	10
7.	Electrical Connection.....	13
7.1	Overview of the Connection Area	13
7.2	Battery Power Connection	13
7.3	BMS Communication Connection	14
7.4	Parallel Connection of Multi-batteries	15
8.	Operating of the Battery	16
8.1	LED Indicator	16
8.2	Turn On/Off the Battery	16
8.3	Maintenance	16
9.	Technical Data	17
	Contacts:	18

1. About This Manual

1.1 Products Covered by This Manual

AIO2-BTLV Series Li-ion batteries.

AIO2-BTLV-5KWH



AIO2-BTLV-10KWH

Target Group

This document is intended for qualified electricians. Any electrical installation and maintenance on this inverter must be performed by qualified electricians in compliance with standards, wiring rules or requirements of local grid authorities or bodies.

1.2 Symbols Used

The following types of safety precautions and general information symbols are used in this manual. These important instructions must be followed during installation, operation and maintenance of the battery.

 DANGER	Indicates a hazard with a high level of risk that will result in death or serious injury.
 WARNING	Indicates a hazard with a medium level of risk that can result in death or serious injury.
 CAUTION	Indicates a hazard with a low level of risk that can result in minor or moderate injury.
NOTICE	Indicates a situation which, if not avoided, can result in property damage.

1.3 Storage of the Manual

The manual should be stored with other documents belonging to the inverter and must be available to people authorized to work on the installation.

2. Safety

2.1 Intended Use

The AIO2-BTLV Series is a lithium battery for an energy storage system. It must only be connected with a SOLTARO hybrid inverter/battery inverter. To prevent personal injury and property damage and to ensure long-term operation of the product, please read and follow all the instructions and cautions on the battery and this user manual during installation, operation or maintenance at all times.

2.2 Important Safety Instructions

DANGER

Danger to life from electric shock.

- Before performing any work on the battery, make sure the battery is powered off and the DC isolator is disconnected.
 - Do not short circuit the DC connectors of the battery, this may cause electric shock to personnel and damage to the product.
 - Do not touch DC connectors of the battery.
 - If an error occurs, contact your local distributor or a qualified electrician.
-

WARNING

- Do not allow the battery to get in contact with liquids.
 - Do not subject the battery to high pressures.
 - Do not place any objects on top of the battery.
-

NOTICE

- Do not open the battery cover or change any components without authorization, otherwise the warranty commitment for the battery will be invalid.
 - Appropriate methods must be adopted to protect battery from electrostatic discharge; any damage caused by ESD is not warranted by the manufacturer.
-

3. Scope of Delivery

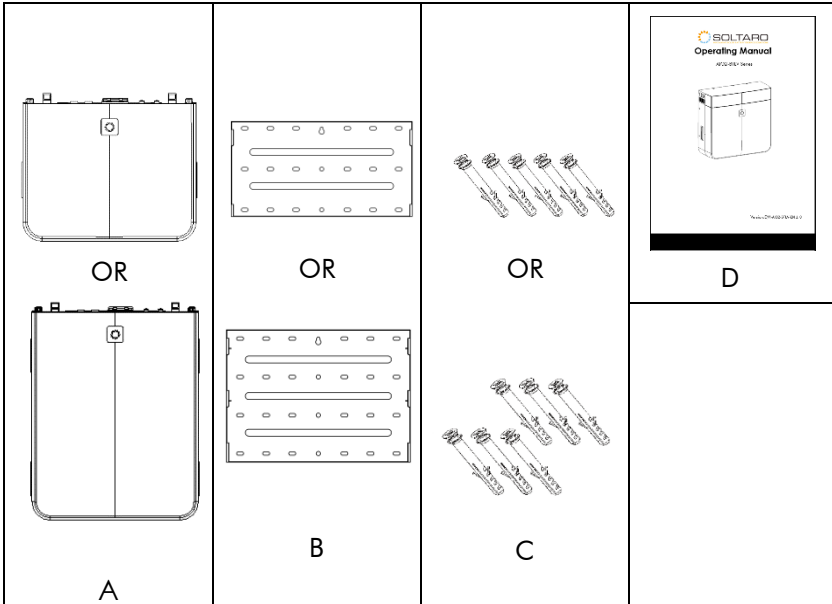

Item	QTY	Designation
A	1	5kWh/10kWh Battery
B	1	5kWh/10kWh Wall Mounting Bracket
C	4	5kWh/10kWh Screws for Fixing Mounting Bracket
D	1	Manual

NOTICE

Accessories for different applications may be different.

4. Product Description

Thank you for choosing a SOLTARO battery. Features of the SOLTARO battery are ahead of the field and should be understood prior to install.

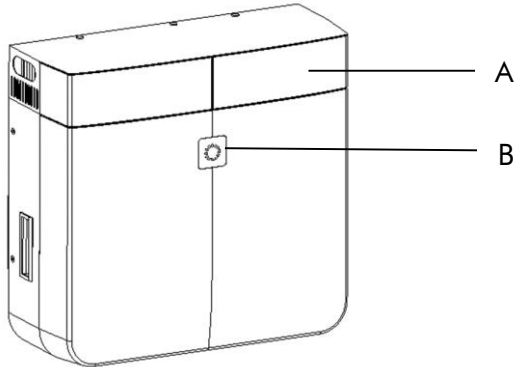





Figure 1. View of the AIO2-BTLV Series Lithium Battery

Position	Designation
A	Connection Area Cover For All-in-one application with hybrid inverter, the cover is not included.
B	LED indicator

Symbols on the Type Label

Symbol	Explanation
	Caution, Risk of Danger
	Caution, Risk of Electric Shock
	Refer to the Operating Manual
	WEEE Mark. This inverter should not be disposed as ordinary waste.

5. Electrical schematic for AIO2-BTLV

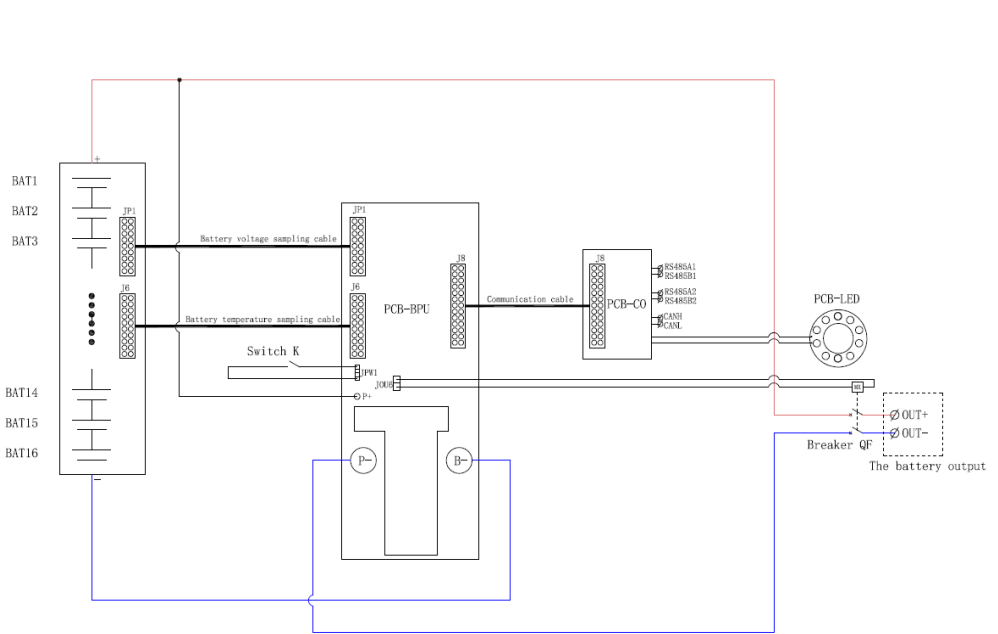

6. Mounting

6.1 Requirements for Mounting

NOTICE

Check to make sure the installation site does not fall into any of the following conditions; If it does, then a risk assessment will be required. Please apply safe lifting procedures when installing the battery. 2 people or mechanical aids are recommended.

- Unsafe due to assessment of occupational health safety risks.
- The ambient temperature is outside the range of tolerable ambient temperature (-20°C to $+50^{\circ}\text{C}$, -4°F to $+122^{\circ}\text{F}$).
- Close to flammable materials or areas where flammable materials are stored. The distance from flammable materials must be $>1200\text{mm}$.

- Prone to be damaged by sea water.
- Prone to be flooded or high levels of snow falls.
- Close to corrosive gas or liquid (for example, locations where chemicals are processed or stored).
- Can be installed indoors or outdoors
- Exposed to direct sunlight or in an enclosure exposed to direct sunlight.
- Little or no air flow
- Mounted on a surface without suitable fire/heat rating.
- Mounted on a wall without suitable load holding capacity.
- High humidity.
- Sites considered unsafe because of local regulations.
- Confined space without adequate airflow.
- Area subject to sand or dust storms.
- Exposed to steam, vapor, or water.

6.2 Mounting the Battery (5kWh)

Procedure:

⚠ CAUTION

The battery must be mounted in upright position with a maximal tilt angle of 15 degree.

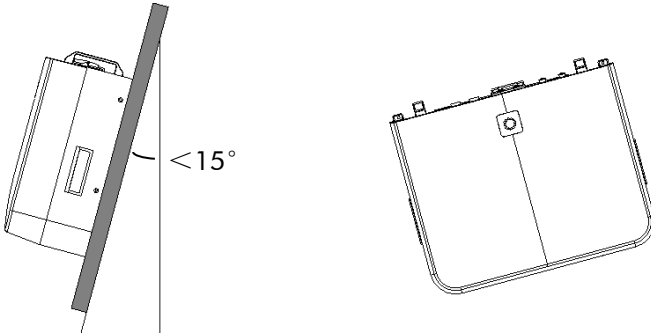

⚠ CAUTION

Space Requirement

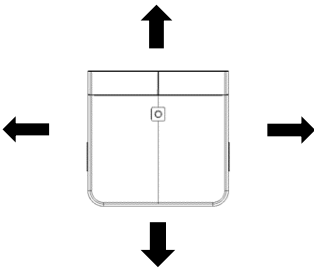

Position	Min.size
Left	600
Right	600
Top	1200 (inverter not included)
Bottom	50
Front	300

STEP 1:

Prepare the battery box and remove the upper cover (fixed by buckle)

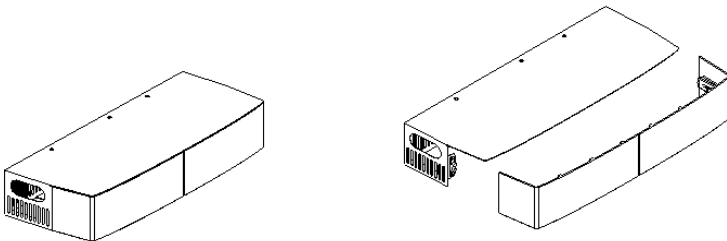

STEP 2:

Install the remaining bottom frame accessories on the 5 kW battery (when installing, take out the 3 rubber plugs on the bottom frame accessories, and then use 3 M5-10 stainless steel cross round head triple combination screws to fix the bottom frame on the battery, and then put back the rubber plug)

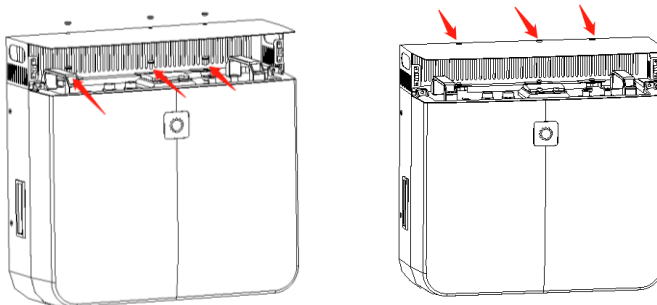

STEP 3 :

Drill holes on the wall (diameter 12mm, drilling depth ≥ 65 mm, unscrew 5 M8-60 expansion screws, and put the expansion head into the drilled hole

note: the height of the drill hole must be ≥ 200 mm

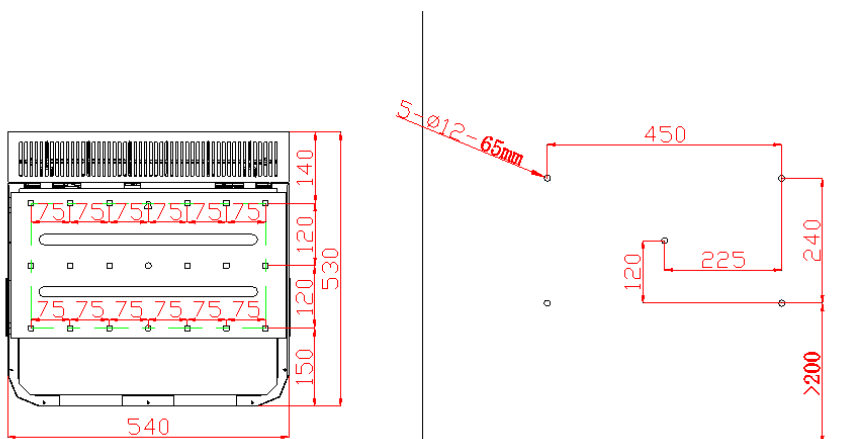

STEP 4:

Install the rack with 5 M8-60 hexagon socket screws unscrewed from the expansion screws in step 3.

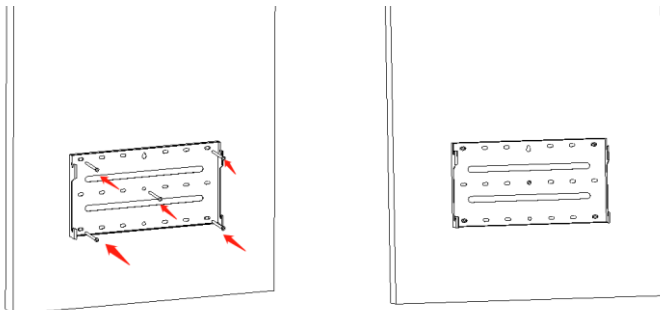

STEP 5:

Hang the battery (note: make sure that the four hanging buckles on the side are locked, otherwise the strength is not enough)

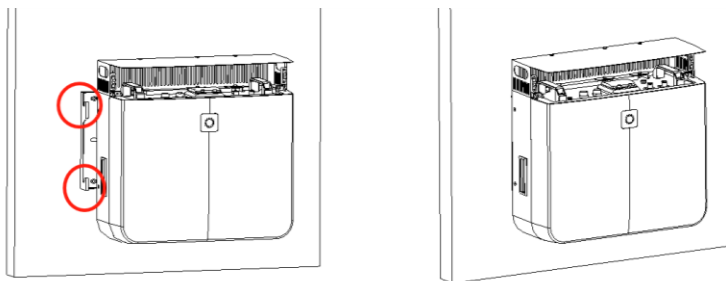

STEP 6:

Install the front cover

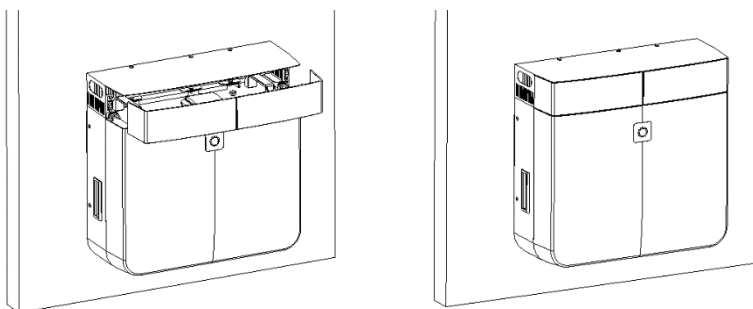

6.3 Mounting the Battery (10kWh)

Procedure:

⚠ CAUTION

The battery must be mounted in upright position with a maximal tilt angle of 15 degree .

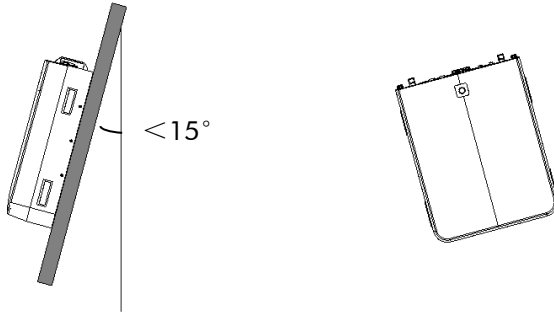

⚠ CAUTION

Space Requirement

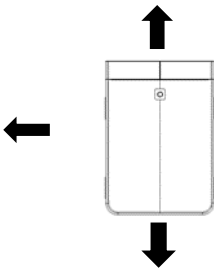

Position	Min.size
Left	600
Right	600
Top	1200 (inverter not included)
Bottom	50
Front	300

STEP 1:

Prepare the battery box and remove the upper cover (fixed by buckle)

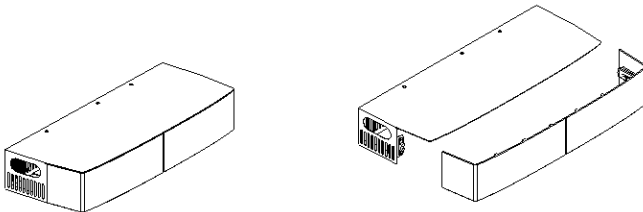

STEP 2:

Install the remaining bottom frame accessories on the 10 kW battery (when installing, take out the 3 rubber plugs on the bottom frame accessories, and then use 3 M5-10 stainless steel cross round head triple combination screws to fix the bottom frame on the battery, and then put back the rubber plug)

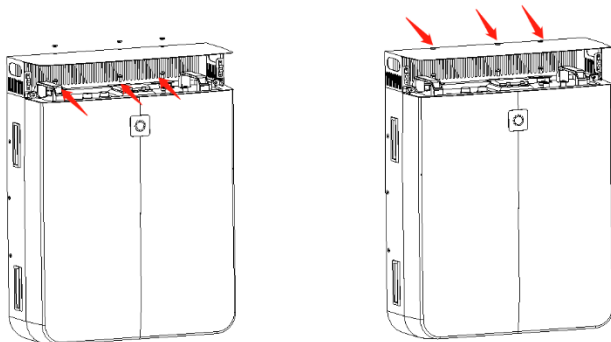

STEP 3 :

Drill holes on the wall (diameter 12mm, drilling depth ≥ 65 mm, unscrew 6 M8-60 expansion screws, and put the expansion head into the drilled hole.

note: the height of the drill hole must be ≥ 200 mm

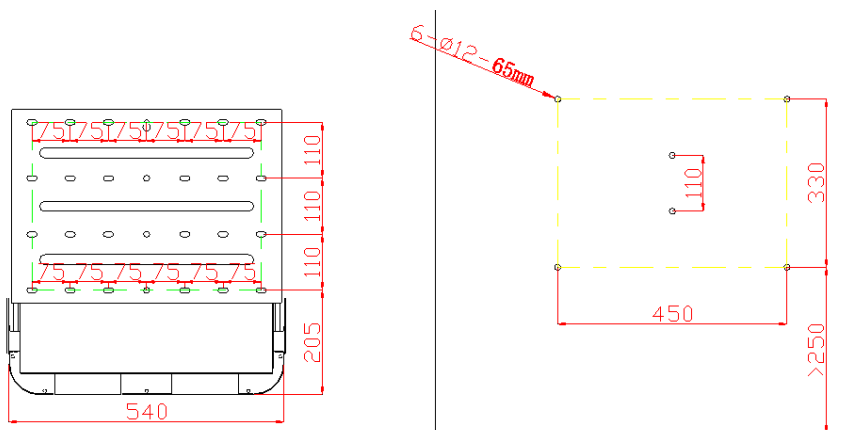

STEP 4:

Install the rack with 6 M8-60 hexagon socket screws unscrewed from the expansion screws in step 3.

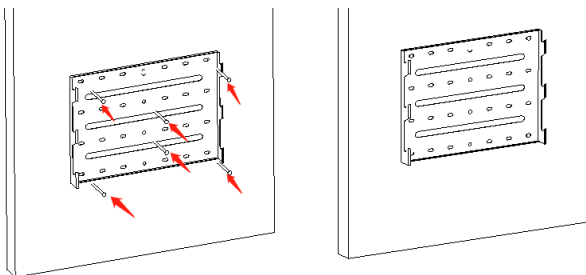

STEP 5:

Hang the battery (note: make sure that the six hanging buckles on the side are locked, otherwise the strength is not enough)

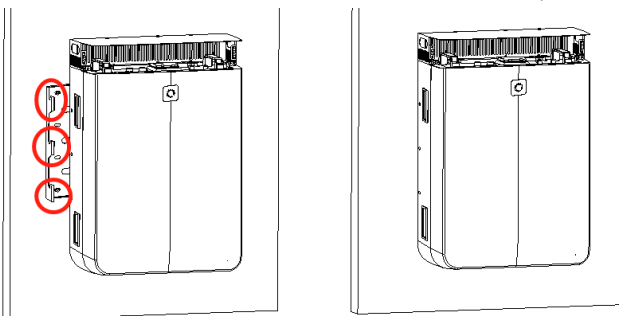

STEP 6:

Install the front cover

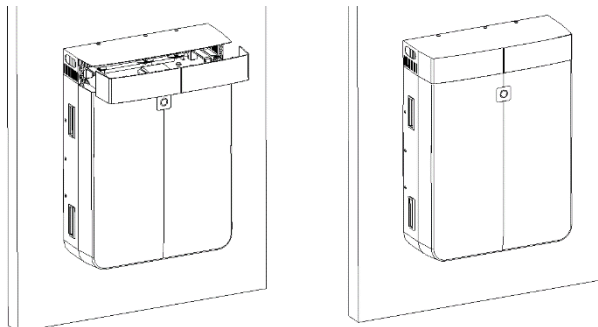

7. Electrical Connection

7.1 Overview of the Connection Area

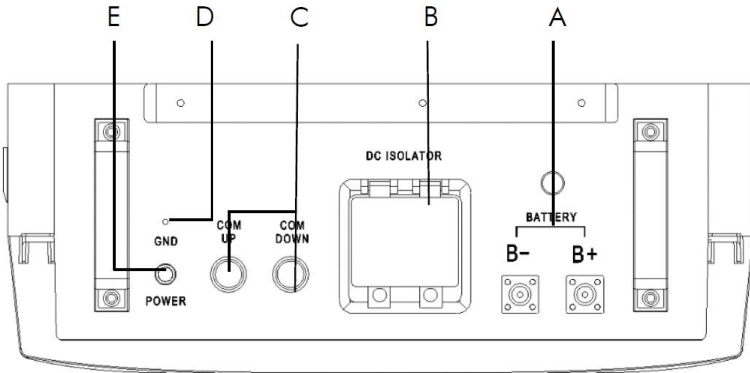

Position	Designation
A	Battery Power Ports
B	DC Isolator (125A)
C	BMS Ports
D	Grounding Port
E	Power Switch

7.2 Battery Power Connection

Battery connection diagram

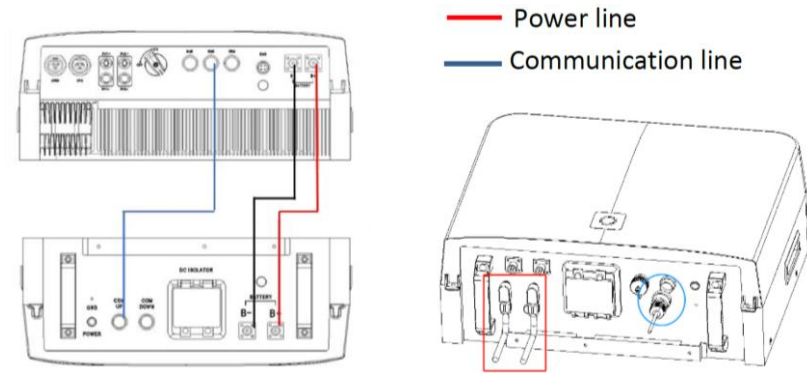

Procedure:

CAUTION

Before connecting the power cable, make sure the battery is turned off, and the DC isolator is disconnected. Power Cables are supplied with included accessories kit, please confirm they are correct before installation.

STEP 1:

- Install the connectors to battery power ports; make sure the polarities are correct.
-

STEP 2:

- Plug the other ends of power cables into inverter. Please contact with your inverter vendor for detailed information.
-

7.3 BMS Communication Connection

Please check whether the BMS communication cable in the accessory box is appropriate for the battery. If you are not sure of that, please confirm with your vendor.

Procedure:

STEP 1:

- Please insert the BMS connector into the BMS port of battery.
-

STEP 2:

- Please insert the other end of the cable in the corresponding port of inverter.
-

BMS Connector Pin Definition:



1. BMS_CAN_H
2. BMS_CAN_L
3. BMS_485_A
4. NULL
5. BMS_485_B
6. NULL

7.4 Parallel Connection of Multi-batteries

Up to 3 units of AIO2-BTLV Series batteries with the same capacity can be parallel connected in one system.

Parallel Connection Diagram

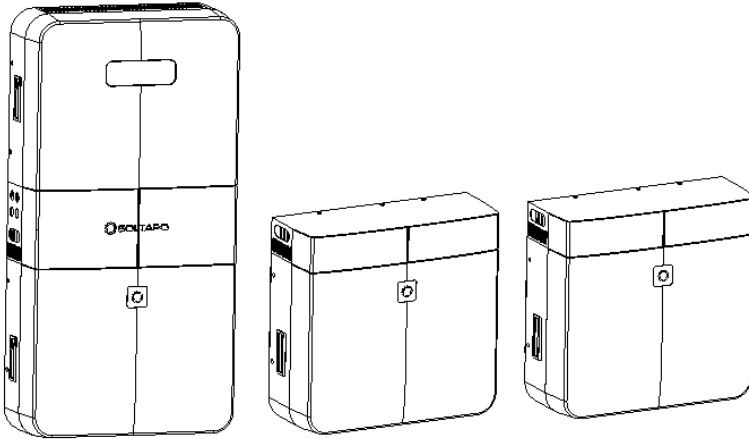

• • • up to 5 units

Procedure:

STEP 1:

- Connect all the positive terminals of power ports of each battery.
- Connect all the negative terminals of power ports of each battery.
- Connect the power ports to inverter.





STEP 2:

- Connect the BMS ports of each battery. The COM DOWN of the first battery should be connected to the COM UP of the second battery and so forth.
 - Then connect the BMS port to inverter.
-

8. Operating of the Battery

8.1 LED Indicator

The LED indicates the operating state of battery and also battery SOC. Battery status can be monitored remotely via inverter monitoring portal when installed with Soltaro Hybrid Inverters.

LED	Explanation
Blue	The battery's status is normal;
	 means SOC= 0~25%(SOC1) SOC1 will flash when charging
	 means SOC=25%+25%~50%(SOC2) when charging, 25% indicator light is on and SOC2 will flash
	 means SOC=50%+50%~75%(SOC3) when charging, 50% indicator light is on and SOC3 will flash
	 means SOC=75%+75%~100%(SOC4) when charging, 75% indicator light is on and SOC4 will flash
Red	•If the battery SOC is below 5%, all the lights will be red.
	•When there is a service alert, all the lights will be red.

8.2 Turn On/Off the Battery

- When turning on the battery, turn on the isolator firstly, then switch on the battery;
- When turning off the battery, switch off the battery firstly, then disconnect the isolator.

8.3 Maintenance

When carrying out battery maintenance, please pay attention to the following matters:

- Only authorized service personnel are allowed to install the battery or perform servicing and maintenance.
- The battery case can be cleaned by dry cloth or soft brush if necessary.
- No electrical maintenance is required.
- The power should be disconnected before attempting any maintenance or cleaning of the battery.

9. Technical Data

Electrical Data	AIO2-BTLV-5KWH	AIO2-BTLV-10KWH
Cell Type	LFP	LFP
Total Energy	5 kWh	10kWh
Depth of Discharge	90%	90%
Usable Energy	5 kWh	10kWh
Nominal Voltage	51.2 V	51.2 V
Operating Voltage Range	40-58.4 V	40-58.4 V
Nominal Capacity	100 Ah	200 Ah
Max. Charge Current	50 A	100 A
Max. Discharge Current	100 A	100 A
Max. Parallel Number	5 units	5 units
General Data	AIO2-BTLV-5KWH	AIO2-BTLV-10KWH
Mounting information	Wall-mounted / Ground-mounted	
Communication	CAN / RS485	
Operating Temperature	0~45°C charge / -10~50°C discharge	
Dimension	540*430*210 mm	540*680*210 mm
Weight	45 kg	85 kg
IP Protection Type	IP65	

Contacts:

Head Office & Showroom

8 Mohr Street, Tullamarine, VIC, Australia 3043

Tel: +61 1300 276 582

Email:

service@soltaro.com Support Head Office

service.au@soltaro.com Australian Support

UK/Europe Office

Unit 8, High Grounds Industrial Est., Worksop, Notts, S80 3AF, United Kingdom

Tel: +44 (0)1909 807 577

Email: service.uk@soltaro.com

South Africa Office

Office 642 Amelia Road, Lanseria Corporate Park, Lanseria South Africa 1739

Tel: +27 (0)11 318 6583

Email: service.sa@soltaro.com

Website

WWW.SOLTARO.COM

Registration URL

<https://soltaro.com/product-registration>